



technical specifications LR18B

general

- High-performance line-array LFE system for medium to larger applications
- Stackable and flyable with LR18 line-array or in separate curved arrays
- Maximum deployment flexibility also in cardioid - and end-fire arrays
- Neodymium dual-coil 18" driver with lowest possible distortion
- SIS™ pre-wired for very high system damping and further reduced distortion
- Front-positioned NL4 connector for easy cardioid connection

description

The LR18B is the dedicated low-frequency extension to the LR18 pro-ribbon line-array. It can also be combined with any other Alcons pro-ribbon system, in both permanent and portable applications.

The front-loaded system delivers a super accurate bass and sub response with highest output under lowest distortion, due to the super long-stroke 18" woofer. This new-generation transducer is fitted with a large, dual- 4.5" voice-coil Neodymium motor, enabling a significantly-extended excursion*, while maintaining a high sensitivity. Specific attention in this design has been paid to obtain lowest possible distortion. The Max-Vent™ port design combines further increased output with low power compression. *(not included in SPL_{peak} spec).

Optimal deployment flexibility is guaranteed: The LR18B can be used as single subwoofer or in multiples; As end-fire or cardioid array; Together with



LR18 or in separate sub-only arrays. All functionality is possible in stacked or flown configurations.

The integrated stand mount adapter provides for easy top/sub combinations with any Alcons pro-ribbon system.

Rated for a high WorkingLoadLimit with 10:1 safety ratio, the versatile rigging system, with front and rear splaying possibility, enables straight or pre-curved flown (cardioid) arrays, to be flown besides or behind an LR18 array.

Array configurations can be simulated through the LR18 GLL in the Alcons Ribbon Calculator (ARC), Alcons' high-resolution 3D simulation program.

Mobile (cardioid) stacks of up to 3 units can be transported through the PRRGLR18B pre-rig, including stack-specific softcover.

For full system performance, the LR18B is to be driven and controlled by the ALC amplified loudspeaker controller; Driven by the ALC, the LR18B delivers full operation flexibility, maximum sound quality and output power with long-term operation reliability.

The Signal Integrity Sensing™ pre-wiring ensures complete cable/connector compensation between the LR18B and ALC, significantly increasing response accuracy and reducing both linear and non-linear distortion to an absolute minimum, regardless of cable length and system impedance.

technical specifications LR18B

dimensional drawing

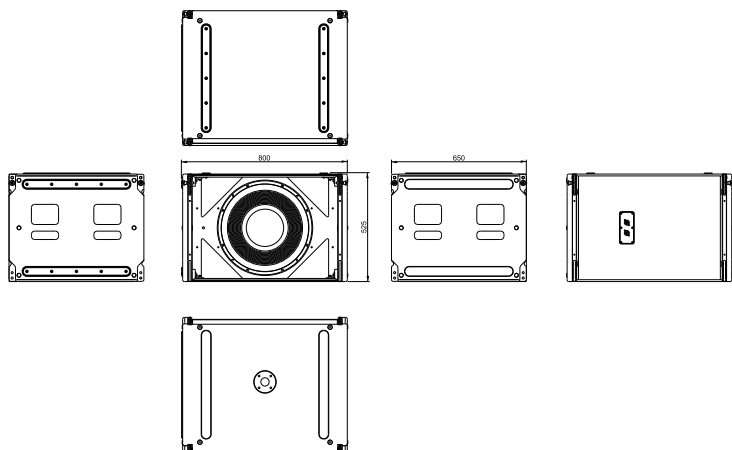

technical specifications

Frequency response	40 Hz - 200 Hz	(+/- 3 dB)
	34 Hz -	(+/-10 dB)
Sensitivity nominal	98 dB (40 - 100 Hz)	
Nominal impedance	8 ohms	
Recommended drive	Sentinel10, max. 3 pcs. per channel (2.7 ohms)	
Nominal SPL peak	124 dB (Sentinel3 40 - 100 Hz)	
	130 dB (Sentinel10 40 - 100 Hz)	
	135 dB (comparative)	
Dispersion H x V	omni / (hyper)cardioid in array with processing	

physical specifications

System	Subwoofer	
Drivers LF	1x AW18.452ND-8 18", vented	
Connectors	3x Speakon NL4 input/link	
Physical dimensions	mm	inches
	Height	525 20.7
	Width	800 31.5
	Depth	650 25.6
Weight (approx.)	45 kg	99.2lb
Warranty	6 years limited	

A: Alcons Audio B.V
De Corantijn 69
1689 AN Zwaag
The Netherlands

E: info@alconsaudio.com
W: www.alconsaudio.com
T: +31 (0) 229 28 30 90
F: +31 (0) 229 28 30 99