

Wharfedale  
Pro

MODEL : DELTA X15M

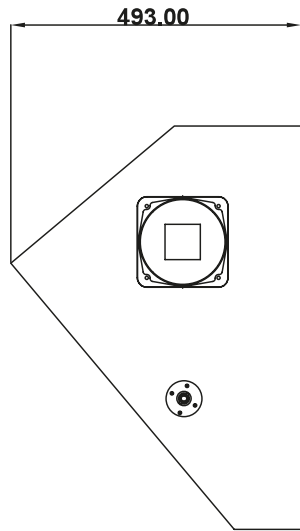

LEFT SIDE VIEW

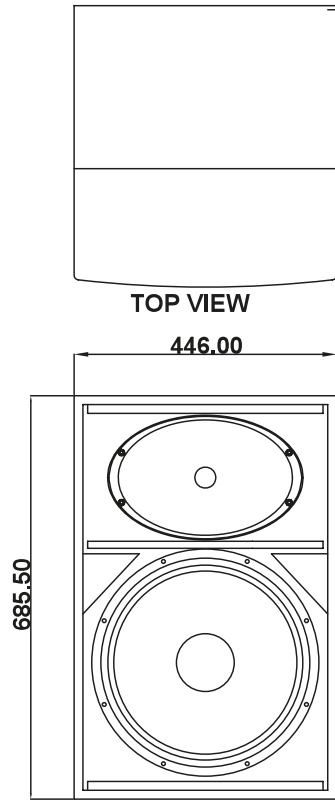

FRONT VIEW

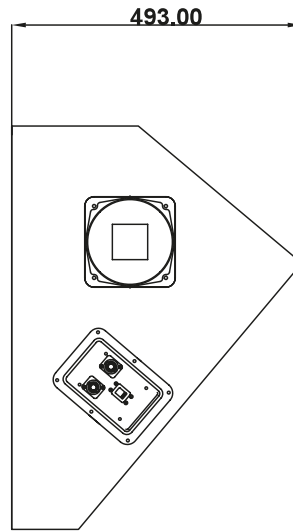

RIGHT SIDE VIEW

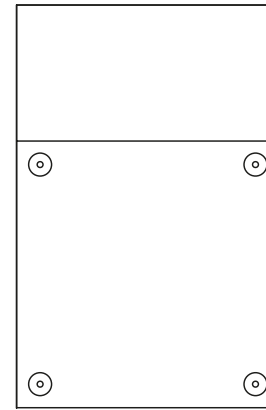

BOTTOM VIEW

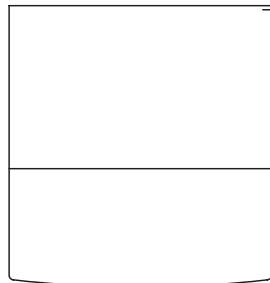

TOP VIEW

System Type	Passive
Configuration	Two-way
Frequency Response (+/-3dB)	55-20KHZ
Frequency Range (- 10 dB)	50-20KHZ
Sensitivity (2.83v/1m)	98dB
Calculated Maximum SPL @1m	131dB
System Rated Impedance	8Ω
<b>Low Frequency Transducer</b>	
Size	404mm / 15" Paper
Voice Coil Size	77.1mm / 3"
Rated Impedance	8Ω
LF Power (re:AES2-2012)	500W
<b>High Frequency Transducer</b>	
HF Driver Type	Compression Driver
Voice Coil Size	50.8mm / 2" Titanium
Exit Size	35.6mm / 1.4"
Diaphragm Material	Titanium
Rated Impedance	8Ω
HF Power (re:AES2-2012)	50W
Nominal Coverage (H x V)	90° x 45°
<b>Power</b>	
System Continuous Power	500W
System Programme Power	1000W
System Peak Power	2000W
Crossover frequency	1.8kHz
Input Connector	2 x NL4 (speakON Compatible)
<b>Hardware</b>	
Pole Mount	
Handles	2 on Sides
Rigging points	-
Enclosure Material	15mm Plywood
Finish	black paint
Grille Material & Finish	1.5 mm Steel Black
<b>Dimensions - Unpacked</b>	
Height	493(SITU)mm / 19.4"
Width Front	446mm / 17.6"
Width Rear	446mm / 17.6"
Depth	685mm / 27.0"
<b>Dimensions - Packed</b>	
Height	518mm / 20.4"
Width Front	757mm / 29.8"
Width Rear	757mm / 29.8"
Depth	565mm / 22.2"
<b>Weight</b>	
Net Weight (kg / lbs)	27.24kg / 59.9lbs
Gross Weight (kg / lbs)	33.96kg / 74.7lbs