

Wharfedale
Pro

MODEL : DELTA X215

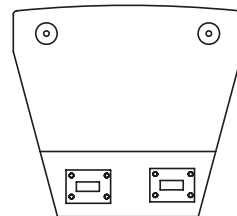
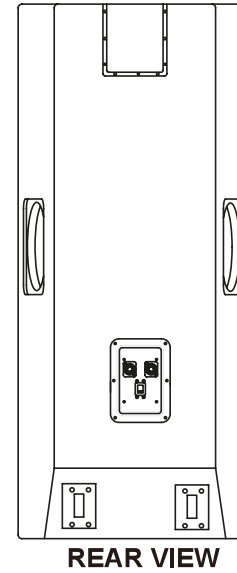
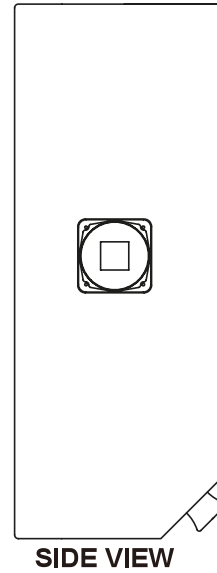
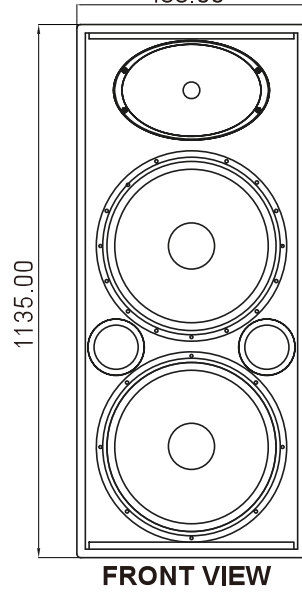
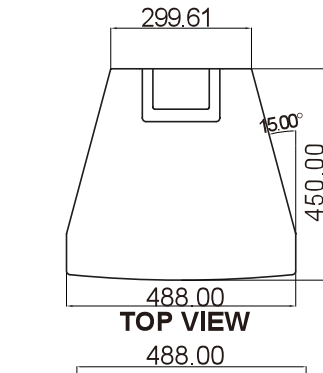

System Type	Passive
Configuration	Quassi Three-way
Frequency Response (+/-3dB)	45-20KHZ
Frequency Range (- 10 dB)	45-20KHZ
Sensitivity (2.83v/1m)	101dB
Calculated Maximum SPL @1m	137dB
System Rated Impedance	4Ω
Low Frequency Transducer	
Size	2 x 404mm / 15"
Voice Coil Size	77.1mm / 3"
Rated Impedance	2x8Ω
LF Power (re:AE52-2012)	2x500W
High Frequency Transducer	
HF Driver Type	Compression Driver
Voice Coil Size	50.8mm / 2"
Exit Size	35.6mm / 1.4"
Diaphragm Material	Titanium
Rated Impedance	8Ω
HF Power (re:AE52-2012)	50W
Nominal Coverage (H x V)	90° x 45°
Power	
System Continuous Power	1000W
System Programme Power	2000W
System Peak Power	4000W
Crossover frequency	1.8Hz
Input Connector	2 x NL4 (speakON Compatible)
Hardware	
Pole Mount	
Handles	2 on Sides / 1 on Back
Rigging points	-
Enclosure Material	15mm Plywood
Finish	black paint
Grille Material & Finish	1.5 mm Steel Black
Dimensions - Unpacked	
Height	1135mm / 44.7"
Width Front	488mm / 19.2"
Width Rear	299.6mm / 11.8"
Depth	450mm / 17.7"
Dimensions - Packed	
Height	1218mm / 48.0"
Width Front	558mm / 22.0"
Width Rear	558mm / 22.0"
Depth	522mm / 20.6"
Weight	
Net Weight (kg / lbs)	52.9kg / 116.6lbs
Gross Weight (kg / lbs)	59.0kg / 130lbs