

Wharfedale  
Pro

MODEL : DELTA X12

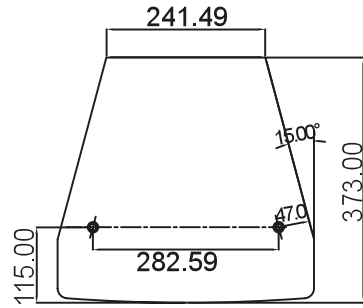

TOP VIEW

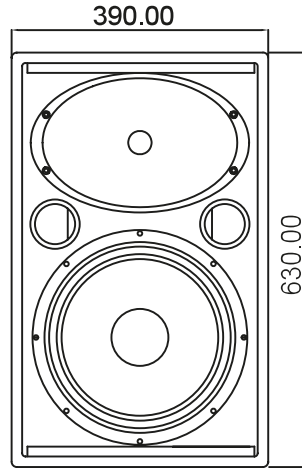

FRONT VIEW

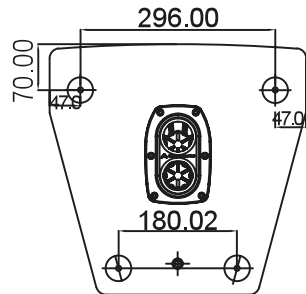

BOTTOM VIEW

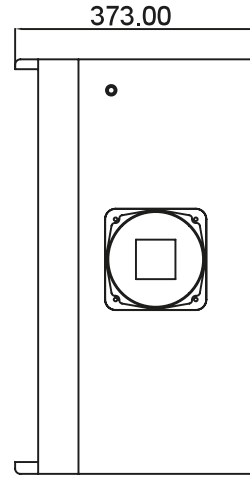

SIDE VIEW

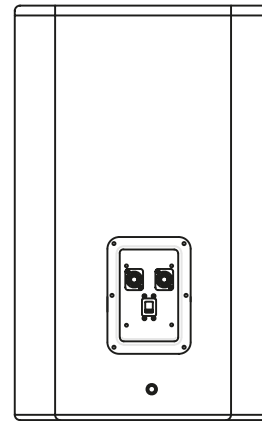

REAR VIEW

System Type	Passive
Configuration	Two-way
Frequency Response (+/-3dB)	60-20KHZ
Frequency Range (- 10 dB)	55-20KHZ
Sensitivity (2.83v/1m)	97dB
Calculated Maximum SPL @1m	129dB
System Rated Impedance	8Ω
<b>Low Frequency Transducer</b>	
Size	332mm / 12" Paper
Voice Coil Size	77.1mm / 3"
Rated Impedance	8Ω
LF Power (re: AES2-2012)	400W
<b>High Frequency Transducer</b>	
HF Driver Type	Compression Driver
Voice Coil Size	50.8mm / 2" Titanium
Exit Size	35.6mm / 1.4"
Diaphragm Material	Titanium
Rated Impedance	8Ω
HF Power (re: AES2-2012)	50W
Nominal Coverage (H x V)	90° x 45°
<b>Power</b>	
System Continuous Power	400W
System Programme Power	800W
System Peak Power	1600W
Crossover frequency	1.8kHz
Input Connector	2 x NL4 (speakON Compatible)
<b>Hardware</b>	
Pole Mount	Dual Angle (0° / 10°) 35mm Socket
Handles	2 on Sides
Rigging points	6 x M10
Enclosure Material	15mm Plywood
Finish	black paint
Grille Material & Finish	1.5 mm Steel Black
<b>Dimensions - Unpacked</b>	
Height	630mm / 24.8"
Width Front	390mm / 15.3"
Width Rear	241.2mm / 9.5"
Depth	373mm / 14.7"
<b>Dimensions - Packed</b>	
Height	773mm / 28.9"
Width Front	566mm / 22.3"
Width Rear	566mm / 22.3"
Depth	464mm / 18.3"
<b>Weight</b>	
Net Weight (kg / lbs)	24.7kg / 54.5lbs
Gross Weight (kg / lbs)	29.0kg / 63.8lbs