

Wharfedale
Pro

MODEL : **TITAN 8**

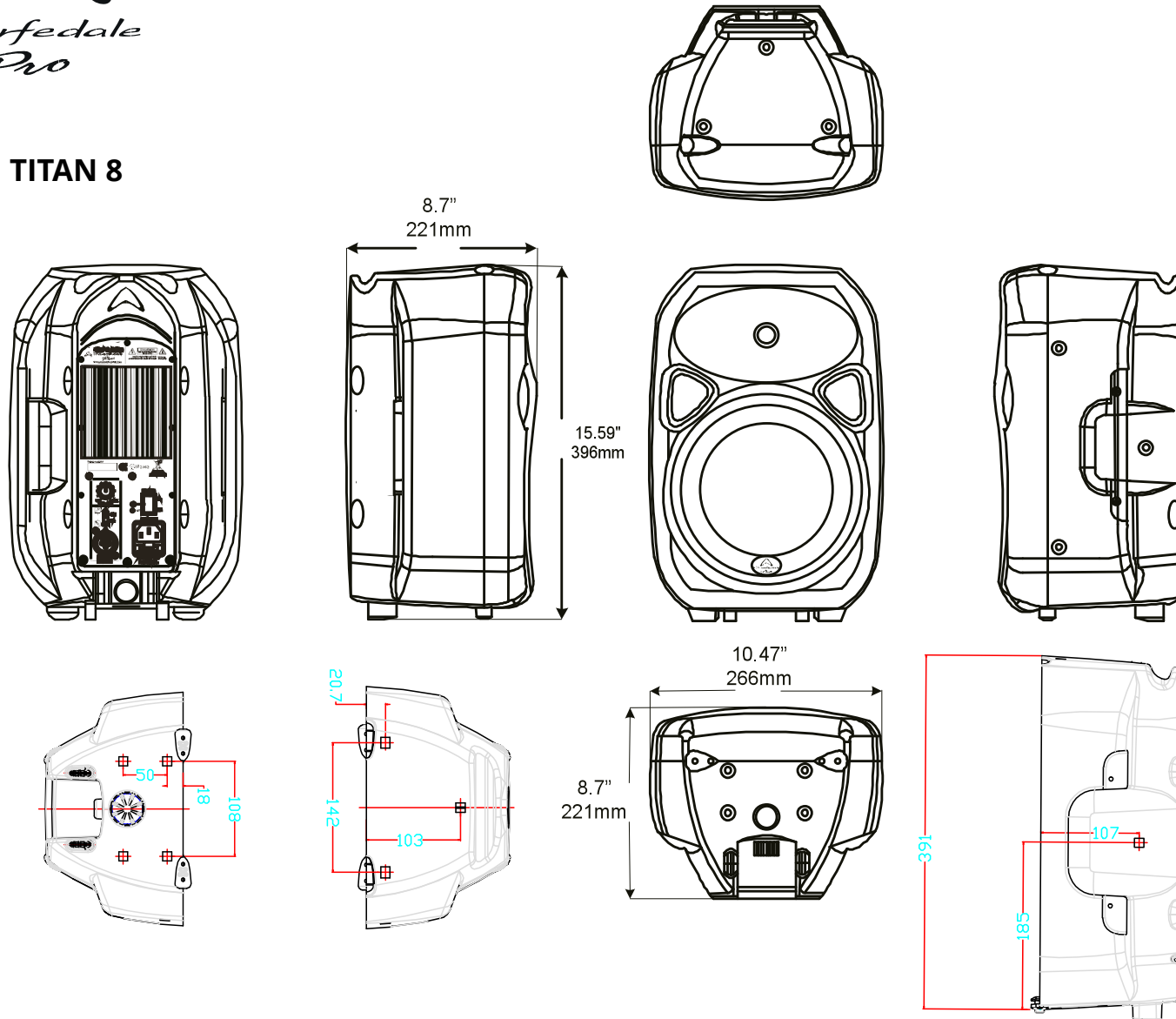

System Type	Passive
Configuration	8" 2-way
Frequency Response (+/-3dB)	70 - 20kHz
Frequency Range (-10 dB)	65 - 20kHz
Sensitivity (2.83v/1m)	96dB
Calculated Maximum SPL @1m	124dB
System Rated Impedance	8Ω
Low Frequency Transducer	
Size	203mm / 8"
Voice Coil Size	38.86mm / 1.53"
Rated Impedance	8Ω
LF Power (re:AES2-2012)	150w
High Frequency Transducer	
HF Driver Type	Compression Driver
Voice Coil Size	25mm / 1"
Exit Size	30mm / 1.2"
Diaphragm Material	Mylar
Rated Impedance	8Ω
HF Power (re:AES2-2012)	20w
Nominal Coverage (H x V)	Elliptical waveguide 90° x 60°
Power	
System Continuous Power	150w
System Programme Power	300w
System Peak Power	600w
Crossover frequency	2-way 2.4kHz / Linkwitz-Riley
Input Connector	2 x NL4 (speakON compatible) / 2 x 1/4"
Hardware	
Pole Mount	35mm with lock screw
Handles	1 on side
Rigging points	M6 * 8
Enclosure	
Enclosure Material	Trapezoidal / Polypropylene
Finish	Grey, Black, White
Grille Material & Finish	
Dimensions - Unpacked	
Height	396mm / 15.59"
Width Front	266mm / 10.47"
Width Rear	266mm / 10.47"
Depth	221mm / 8.7"
Dimensions - Packed	
Height	463mm / 18.2"
Width Front	325mm / 12.8"
Width Rear	325mm / 12.8"
Depth	282mm / 11.1"
Weight	
Net Weight (kg / lbs)	5.5kg / 12.1 lbs
Gross Weight (kg / lbs)	7.5kg / 16.5 lbs