

Wharfedale
Pro

MODEL : Typhon-AX12

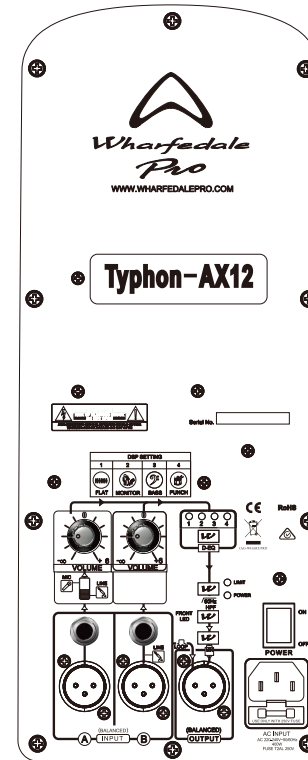
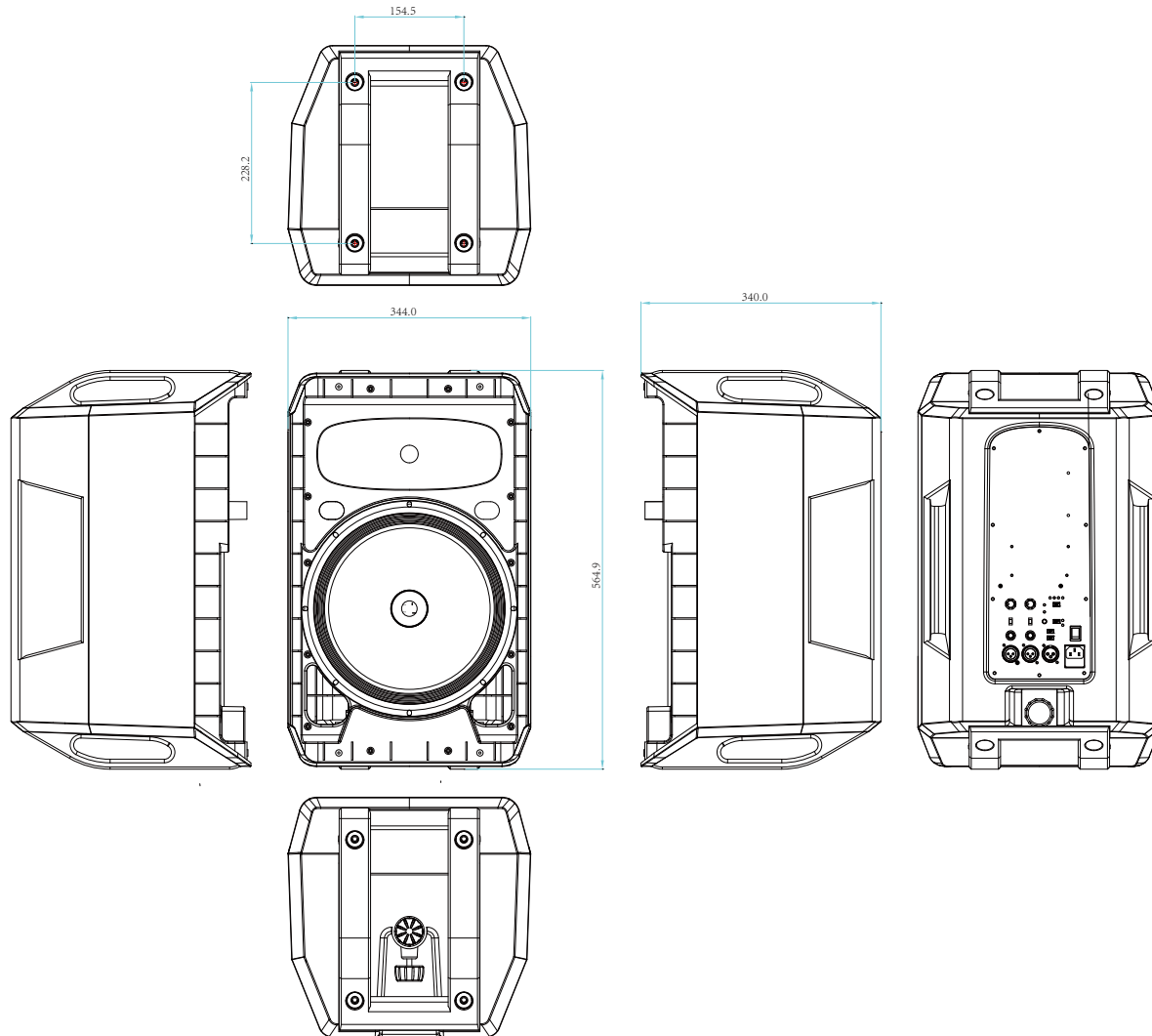

Rear Panel

Model Name	Typhon-AX12
System Type	Active 12" 2-way
Frequency Response (+/-3dB)	55Hz-20KHz
Frequency Range (-10 dB)	50Hz-20KHz
Maximum SPL (peak @1m)	129dB
Sensitivity (@ 1W / 1m)	98dB
Low Frequency Transducer	
Size (mm / inches)	305mm / 12"
Voice-Coil Size (mm / inches)	65mm / 2.5"
Rated Impedance	4Ω
High Frequency Transducer	
HF Driver Type	Compression Driver
Coil Size (mm / inches)	44mm / 1.75"
Exit Size (mm / inches)	25mm / 1"
Diaphragm Material	Titanium
Rated Impedance	8Ω
Nominal Coverage (H x V)	Hybrid Symmetry Horn 100° x 80°
Amplifiers	
Amplifiers	2 x Class D
Power Rating:	140W Peak (1200W LF + 240W HF), 720W Continuous (600W LF + 120W HF)
DSP Controls--D-EQ	FLAT/MONITOR/BASS/PUNCH
Amplifier Protection	
Power On Protection	Yes
Thermal Protection	Yes
Low Line Voltage Shut Down	Yes
Driver Protection	Yes
DC Protection	Yes
Short Protection	Yes
Clip Limiter	Yes
Limiter Indicator	Yes
Power Indicator	Yes
Inputs	
Input A - type	Balanced
Input Sensitivity	775mV (0dBu)
Maximum Input Level	4V
Input Connectors	2 x XLR, 2 x 6.3mm (Line/MIC)
Input Impedance	20K ohms
Line Output	
Line Output Connector	XLR
Loop Gain	0dB
AC Power details	
Power Supply	220-240VAC / 100-120VAC 50/60Hz
Rigging / Bracket / Mounting Options	9 x M8 threaded inserts Pole-mount receptacle with lock screw Optional WPB-2 wall-mount bracket
Handles	
Handles	4 carry handles (on top and bottom side)
Enclosure	
Enclosure Material and finish	Injection Moulded Polypropylene
Colour Options	Black paint
Grille Material & Finish	steel
Dimensions - Unpacked (mm / inches):	
Height	558mm / 22.0"
Width Front	344mm / 13.6"
Width Rear	245mm / 9.6"
Depth	340mm / 13.4"
Dimensions - Packed (mm / inches):	
Height	645mm / 25.4"
Width Front	425mm / 16.7"
Width Rear	425mm / 16.7"
Depth	419mm / 16.5"
Net Weight (kg / lbs)	16.2kg / 35.6lbs
Gross Weight (kg / lbs)	18.9kg / 41.6lbs